

General Specifications

Model VJQ8 Pulse to Analog Converter (Isolated Single-output and Isolated Dual-output Types)



GS 77J01Q08-01E

General

This plug-in type pulse to analog converter receives contact pulse, voltage pulse, or current pulse from the field and converts the signal into isolated DC current or voltage signals.

- Output-2 can be selected from DC voltage signal, DC current signal, communication function (RS-485), or alarm output (2 relay contacts).
- Various parameters such as input range can be set and modified using a PC (VJ77) or Handy Terminal (JHT200 and the like).
- A pulse integration function that converts integrated flow value (average pulse frequency) through specified sampling time into analog signals is provided.

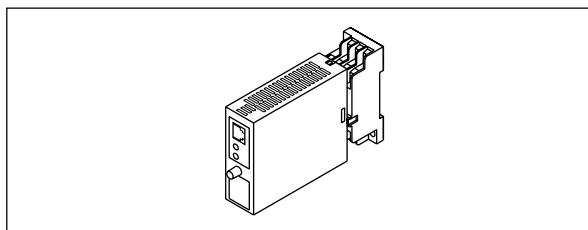

Model and Suffix Codes

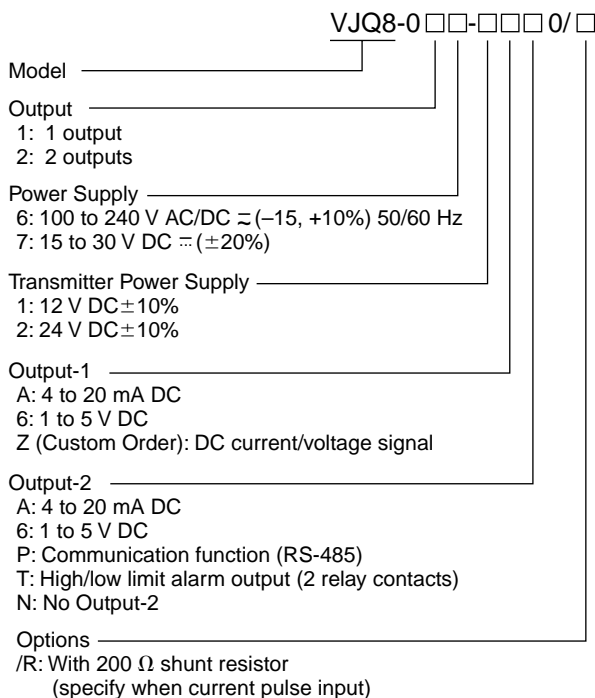

Input signal type:

	Non-voltage contact	
ON input	Contact resistance of 200 Ω or less	
OFF input	Contact resistance of 100 Ω or more	
	Voltage pulse	Current pulse (Note1)
High level (OFF input)	2 to 50 V DC	10 to 50 mA DC
Low level (ON input)	-1 to +8 V DC	-5 to +40 mA DC
Pulse width	2 to 50 V DC	10 to 50 mA DC

Note 1: Maximum permissible current is 50 mA for 200 Ω shunt resistor.

Maximum permissible input voltage: 58 V DC or less

Lowcut point: 0.01 Hz to 100% of input frequency

Input resistance:

Contact or voltage pulse; 15 k Ω or more

Current pulse; 200 Ω (external shunt resistance: options)

Minimum input pulse width:

30 μ s for less than 10 kHz of input frequency

30% of pulse interval for 10 kHz or more of input frequency

Contact input signal rated supply: 15 V DC/15 mA or more

Input filter: Approx. 10 ms of time constant (On/off can be set)

Transmitter power supply: 12 V DC \pm 10% (4 to 30 mA output) or 24 V DC \pm 10% (4 to 30 mA output) (with current limit circuit at 50 mA)

Pulse count point: Turning point from Off input to On input
Input conversion mode: Can be selected from F/V conversion or pulse integration

F/V conversion: Converts 0 to 100% of frequency inputs into 0 to 100% analog outputs

Pulse integration: Calculates average frequency from integrated pulse counts for preset sampling time, then converts 0 to 100% of frequency inputs into 0 to 100% analog outputs

Sampling mode: Can be selected from AUTO or MANUAL

Input

Input signal: 2-wire type ON/OFF contact, voltage pulse, current pulse (transmitter power supply available) or 3-wire type voltage pulse (transmitter power supply available).

Input frequency: 0.1 Hz \leq F₁₀₀ \leq 100 kHz and
0 Hz \leq F₀ \leq F₁₀₀

Where F₀ is 0% of and F₁₀₀ is 100% of input frequency.

F can be set in increments of 0.00001 (Hz or kHz) within 4 significant digits.

Input range unit: Selectable from Hz and kHz

Sampling time: 0.1 to 100 sec in increments of 0.1 sec
 However when in AUTO mode, sampling time is not preset, but is forcibly determined as follows:
 0.1 sec when F_{100} is 1 kHz or more;
 $(1/F_{100}) \times 100$ sec when F_{100} is more than 1 Hz and less than 1 kHz; and
 100 sec when F_{100} is 1 Hz or less.
 Where F_{100} is 100% of input frequency.
 Output response: Sampling time + 100 ms

Output

1. Output-1

Output Signal	Output Resistance	Permissible Load Resistance
1 to 5 V DC	1 Ω or less	2 kΩ or more
4 to 20 mA DC	500 kΩ or more	750 Ω or less

- **Custom Order Output Signal**
 2 to 10 mA DC, 1 to 5 mA DC, 0 to 20 mA DC,
 0 to 16 mA DC, 0 to 10 mA DC, 0 to 1 mA DC
 0 to 10 mV DC, 0 to 100 mV DC, 0 to 1 V DC,
 0 to 10 V DC, 0 to 5 V DC, -10 to +10 V DC

2. Output -2

● **Analog Output**

Output Signal	Output Resistance	Permissible Load Resistance
1 to 5 V DC	1 Ω or less	2 kΩ or more
4 to 20 mA DC	500 kΩ or more	350 Ω or less

● **Communication Function**

This transmitter can be connected to a PC, graphic panel, YOKOGAWA programmable controller FA-M3, or programmable controllers of other manufacturers.

- Standards: EIA RS-485
- Maximum number of connectable units: 31 units
- Maximum communication distance: 1200 m
- Communication method: 2-wire half duplex, start-stop synchronization, non-procedural
- Communication rate: 1200, 2400, 4800, 9600 bps
- Data length: 8, 7 bits
- Stop bit: 1, 2 bits
- Parity: Even parity, odd parity, or none
- Communication protocol: PC-link, PC-link with SUM, MODBUS ASCII, MODBUS RTU, or LADDER
- PC-link communication: Communication protocol with a PC, graphic panel, UT link module of FA-M3
- MODBUS communication: Communication protocol with a PC (SCADA).
- Ladder communication: Communication protocol with ladder communication module of FA-M3 and programmable controller of other manufacturers

● **Alarm Output**

- Signal type: Relay contact
- Output signal: N. O. contact output (contact ON at excitation)
 2 points, COM common

- Contact capacity: 30 V DC, 1 A
- Alarm operating direction: High limit alarm or low limit alarm
- Relay operating direction setting: Excitation or non-excitation at normal status
- Alarm setting range: 0 to 100% of input range
 Setting resolution: 0.1%, 4 significant digits
- Hysteresis setting range: 0 to 100% of input range
 Setting resolution: 0.1%, 4 significant digits
- Alarm on-delay setting: Delay time from alarm condition completion to output
 (Ex. Outputted when alarm status continues for 1 second or more after input value is over alarm point in case of set value "1 second.")
 Setting range: 0 to 999 seconds
 Setting resolution: 1 second (however, add about 0.2 second to setting time to prevent wrong operation)
- Alarm off-delay setting: Delay time from alarm normal condition completion to output
 (Ex. Released when normal status continues for 2 seconds or more after input value comes back to normal status from alarm status in case of set value "2 seconds.")
 Setting range: 0 to 999 seconds
 Setting resolution: 1 second (however, add about 0.2 second to setting time to prevent wrong operation)
- Alarm operation display: Front LED lights at alarm, 2 LEDs

Items Available to Be Set

The following items can be set via a PC (VJ77 PC-based parameters setting tool) or Handy Terminal (JHT200 and the like):

Conversion mode, range units, input frequency, lowcut points, input filter, sampling mode, sampling time, address number, baud rate, parity, data length, stop bit, protocol, alarm operating direction, relay operating direction, alarm setting, hysteresis, alarm on-delay and alarm off-delay

Standard Performance

- Accuracy rating: ±0.1% of span
 However, accuracy is limited when zero elevation is 50% or more.
 $Accuracy (\%) = (F_{100}/2)/(F_{100} - F_0) \times 0.1$
- Response speed: 2 intervals of input pulse + 100 ms
 63% response (10% to 90%) when in F/V conversion mode
- Effect of power supply voltage fluctuation: ±0.1% or less of span for power supply voltage fluctuation of 85 to 264 V AC (47 to 63 Hz)/DC and 12 to 36 V DC
- Effect of ambient temperature change: ±0.2% or less of span for change of 10°C

Safety and EMC Standards

- Safety: Approved by CSA1010, approved by UL3121-1.
- Installation category: CAT. II (CSA1010)
- Pollution degree: 2 (CSA1010)

As for the apparatus authorized, power supply voltage is limited to 15 V to 30 V DC, and the circuit to connect is limited to a class 2. (UL3121-1)

Category	Description	Remarks
CAT. I	For measurements performed on circuits not directly connected to MAINS.	
CAT. II	For measurements performed on circuits directly connected to the low voltage installation.	Appliances, portable equipments, etc.
CAT. III	For measurements performed in the building installation.	Distribution board, circuit breaker, etc.
CAT. IV	For measurements performed at the source of the low-voltage installation.	Overhead wire, cable systems, etc.

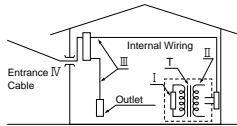

EMC Standards: Complies with EN61326.

The above conformed instrument is only for voltage of 15 to 30 V DC \pm (±20%).

Power Supply and Isolation

Power Supply Rated Voltage:

100 to 240 V AC/DC \approx 50/60 Hz
15 to 30 V DC \pm

Power Supply Input Voltage: 100 to 240 V AC/DC \approx

(-15, +10%) 50/60 Hz
15 to 30 V DC \pm (±20%)

Power Dissipation: 24 V DC 4.1 W, 110 V DC 4.1 W

100 V AC 6.0 VA, 200 V AC 7.3 VA

Insulation Resistance: 100 M Ω /500 V DC between input, output-1, output-2, power supply and ground mutually

Withstand Voltage: 2000 V AC / minute between input, (output-1, output-2), power supply, and ground mutually

1000 V AC / minute between input and output-2 when alarm output

1000 V AC / minute between output-1 and output-2

Environmental Conditions

Temperature: 0 to 50 °C (0 to 40°C when 2 current-output is selected and side-by-side close installation.)

Humidity: 5 to 90% RH (no condensation)

Ambient Condition: Avoid installation in such environments as corrosive gas like hydrogen sulfide, dust, sea breeze and direct sunlight.

Installation altitude 2000 m or less above sea level.

Timing Chart of Pulse Integration Operation

This timing chart shows an example of the integration operation where input frequency is 0 to 10 Hz and sampling time is 2 sec.

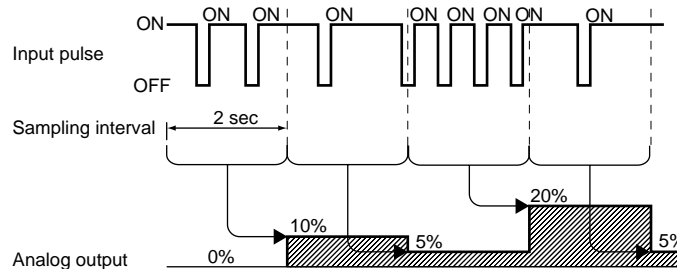

Mounting and Appearance

Construction: Compact plug-in type

Material: Modified Polyphenylene Oxide (Case body)

Mounting Method: Wall, DIN rail, or dedicated VJ mounting base mountings (only when output-2 is analog output.)

Connection Method: M3 screw terminal

External Dimension: 29.5×76×124.5mm (W×H×D)

Weight: Approx. 170 g

Standard Accessories

Tag number label: 1

Range label: 1

Shunt resistor: 1 (when optional code /R is specified)

Items to Specify When Ordering

The conversion mode, range units, input frequency, lowcut point, input filter on/off setting, sampling mode and sampling time are set as specified before shipment.

- Model and suffix codes: e.g. VJQ8-026-1AA0
- Conversion mode: e.g. F/V conversion
- Input frequency: e.g. 0 to 10 Hz
- Low cut point (Hz): e.g. 0.01
- Input filter: e.g. OFF

* When specifying F/V conversion, the specifications of sample mode, sample time are unnecessary.

Factory Setting

Factory settings are as follows:

- Conversion mode: F/V conversion
- Input frequency: 0 to 10 Hz
- Low cut point (Hz): 0.01
- Input filter: Off
- Sampling mode: AUTO
- Sample time: 10

When output-2 is specified as communication output

- Address No.: 01
- Baud rate: 9600 bps
- Parity: Even
- Data length: 8 bits
- Stop bit: 1 bits
- Protocol: PCLINK

When output-2 is specified as alarm output

- Alarm operating direction: High limit alarm (alarm-1), low limit alarm (alarm-2)
- Relay operating direction: Excitation at alarm (alarm-1 / 2)
- Alarm setting: 100% (alarm-1), 0% (alarm-2)
- Hysteresis: 3% (alarm-1 / 2)
- Alarm on-delay: 0 second (alarm-1 / 2)
- Alarm off- delay: 0 second (alarm-1 / 2)

Terminal Arrangement

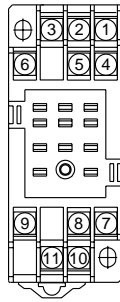

Terminal No.	Signal	Output-2 analog output	Output-2 communication output	Output-2 alarm output
1	Input		(PS+)	
2	Output-2	(+)	B (+)	ALM1
3	Input		(+)	
4	Input		(-)	
5	Output-2	(-)	A (-)	COM
6	Output-2	Not connected	COM	ALM2
7	Output-1		(+)	
8	GND		GND	
9	Output-1		(-)	
10	Power supply		(L+)	
11	Power supply		(N-)	

Note 2: With the one-output type, terminals for Output-2 are not connected.

Block Diagram

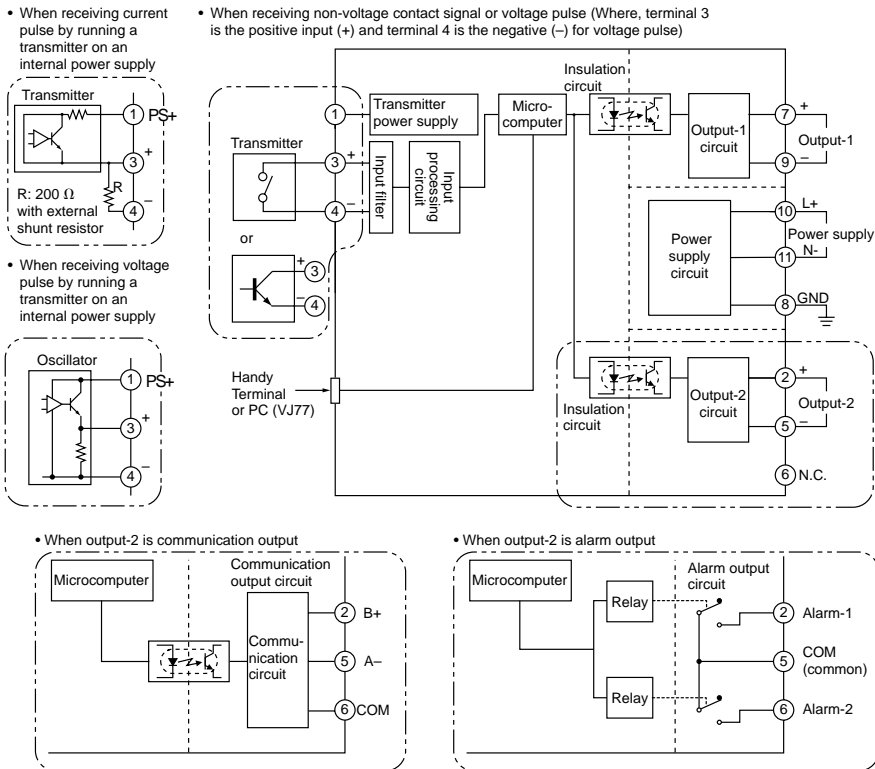

External Dimensions

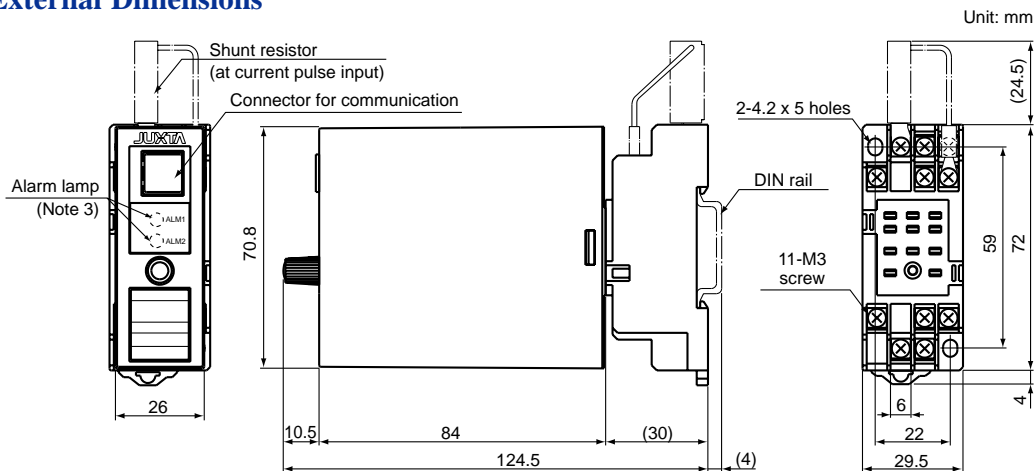

Note 3: Only when output-2 is alarm output.